

# T&C XL Series

## 50, 75 and 100 GPM HDPE FUR-HAIR Interceptors

Function: Solids and FUR-HAIR interceptors are required anywhere that solids, hair or fur may be introduced into the public sewer system in applications such as: barber shops, dentist offices, salons, artist studios, laundry facilities, etc. These wastes must be separated before entering the sewer system. Typically installed either on or into the floor. Narrow width permits access through doorways and down stairwells. High Density Polyethylene construction ensures a lightweight installation process (two people can move and install it). Regular maintenance is required to keep the interceptor functioning. All XL interceptors can withstand a temperature of up to and including 180 degrees Fahrenheit.

Unit shall include: dual strainer baffles with 3/8" Dia. holes, 1/2" apart, deep seal trap covered by lid, adjustable lid system, sample port access and 4" no hub inlet and outlet connections. Steel encased composite lid provides a water / gas tight seal and has a minimum of 20,000 lbs. load capacity. The lid is designed in accordance with the loading requirements of AASHTO H20.

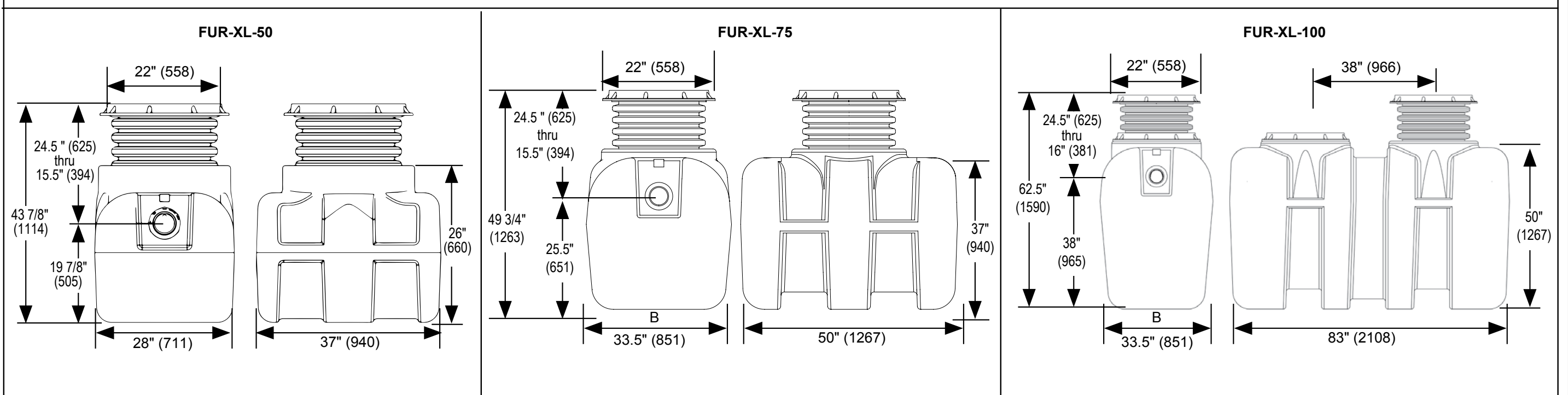
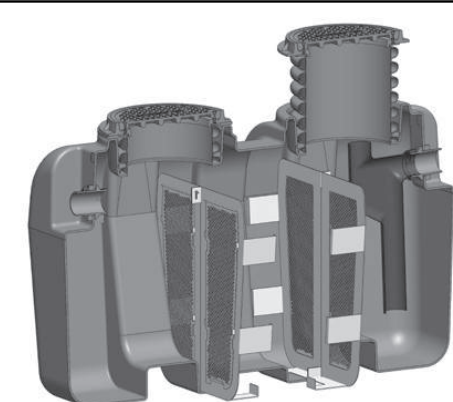
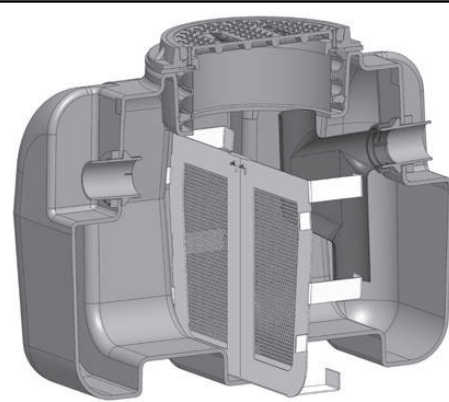

Model No.	LIQUID CAP. (Gallons / Cu. Ft.)	SOLIDS CAP. (Gallons / Cu. Ft.)	B Width	Shipping Weight (lbs.)
FUR-XL-50	55 / 7.19	28 / 4	28.00"	92
FUR-XL-75	140 / 18.30	70 / 9	33.50"	165
SLD-XL-100	300 / 39.21	150 / 20	33.50"	290

OPTIONAL VARIATIONS	PART NO.
Anchor kit for XL Series	XL-AK
Lid Extension - up to 44" high - for XL Series	XL-EXT-44
Lid Extension - up to 72" high - for XL Series	XL-EXT-72
6" no hub inlet and outlet - for each piece (two pieces required)	XL-F6
High level alarm and float switch (to be installed on site)	XL-RPOK
Remote pump out kit (also includes Remote Pump Out (-RPO))	XL-RPO
3" Remote pump outlet connections on top of interceptor - specify location and number required	XL-HLA
External sampling port - inline, high connections	XL-SP-H
External sampling port - inline, low connections	XL-SP-L
External sampling port - offset	XL-SP-OF

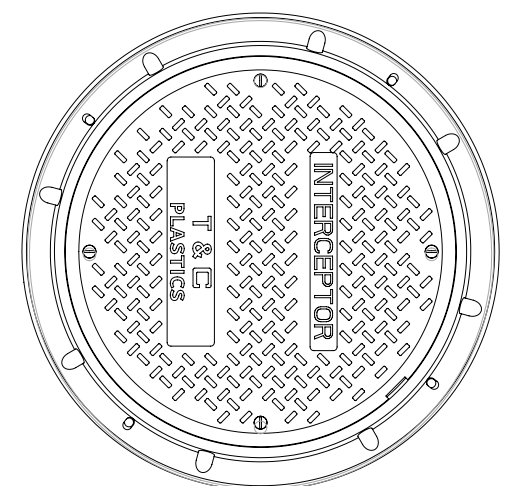

UNLESS STATED OTHERWISE DIMENSIONS ARE IN INCHES	MATERIAL: HDPE		TITLE: XL Series FUR-HAIR Interceptor		SERIES: XL SERIES	REV:	 WWW.TANDCPLASTICS.COM 732-780-5300
	WEIGHT [lb]:		NAME: DR	DATE: 11/15/2022	SHEET 1 OF 1	SIZE:	
	DO NOT SCALE DRAWING		CHECKED:			SCALE: 1:2	