

**Specification:** T&C Plastics SS- \_\_\_\_\_ (indicate model) gravity oil / sediment interceptor with liquid holding capacity of \_\_\_\_\_ (indicate), limited lifetime warranty and is made in the U.S.A. out of seamless, rotationally molded High Density Polyethylene with 3/8" uniform wall thickness. Interceptor is designed for below ground installation (the 2000 gallon model can only be installed below ground) and includes an adjustable top assembly system, sample port access, deep seal trap covered by "special duty" load rated (over 10,000 lbs.) ductile iron top inlet grates, sediment bucket (1/4" diameter holes) within top assembly, internal air relief by-pass, sample port access, base for support and 4" no hub outlet connection. The high density polyethylene material is PE 3135 from Dow 9.39 with a density of 0.939 g/cm3. For indoor/outdoor use.

**Function:** Oil / sediment interceptors are required anywhere oil and sediment may be introduced to the public sewer system in applications such as: repair garages, oil change stations, car wash facilities, parking garages and facilities where oil and flammable liquid waste are produced as a result of manufacturing, storage, maintenance, repair or testing processes. Sediment and debris are collected inside of the internal sediment bucket. Regular maintenance is required to keep the interceptor functioning. Interceptor to be installed flush with the floor. Standard SS models are made with "special duty" load rated (over 10,000 lbs.) ductile iron top inlet grates. The optional -SI models are made with an 4" no hub inlet opposite the outlet.

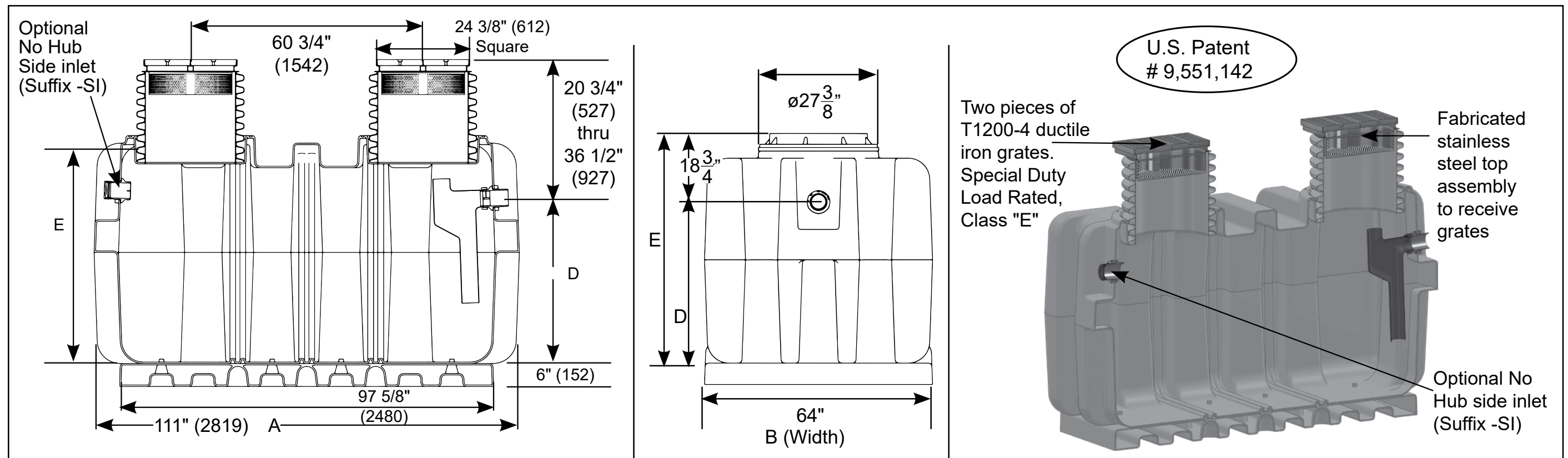

Model	Liquid Holding Capacity (Gallons)	A	B Width	D Dim.	E Dim.	F Outlet Connection Size	Shipping Weight (lbs.)
OO-SS-500	500 (1,890 litres)	111" 2820mm	64" 1630mm	24.25" 616mm	40 1/2" 1029mm	4" 102mm	1060
OO-SS-750	750 (2,840 litres)	111" 2820mm	64" 1630mm	32.88" 835mm	49 1/8" 1248mm	4" 102mm	1,125
OO-SS-1000	1,000 (3,790 litres)	111" 2820mm	64" 1630mm	43.25" 1099mm	59 1/2" 1511mm	4" 102mm	1,185
OI-SS-1300	1,300 (4,921 litres)	111" 2820mm	64" 1630mm	54.25" 1378mm	70 1/2" 1791mm	4" 102mm	1,260
OI-SS-1500	1,500 (5,688 litres)	111" 2820mm	64" 1630mm	62" 1575mm	78 1/4" 1988mm	4" 102mm	1,360
OI-SS-2000	2,000 (7,570 litres)	111" 2820mm	64" 1630mm	83.50" 2121mm	99 3/4" 2534mm	4" 102mm	1,460

Suffix	Optional Variations
-AK	Anchor kit (set of two)
-C	Lid Extension (specify dimension required)
-DI	Ductile Iron lid & collar
-FL-C	Membrane clamp kit
-F6	6" No Hub connections (for each piece)
-F8	8" No Hub connections (for each piece) Fabricated stainless steel
-HLA	High level alarm and float switch (to be installed on site)
-LHSI	4" no hub inlet on left hand side
-LHSO	4" no hub outlet on left hand side
-O	Optional 4" outlet connection
-POK	Remote pump out kit
-RHSI	4" no hub inlet on right hand side
-RHSO	4" no hub outlet on right hand side
-RPO	4" Remote pump outlet connections on top of interceptor - specify location and number required
-SP	External sampling port - inline, high connections
-SP-L	External sampling port - inline, low connections
-SP-OF	External sampling port - offset

UNLESS STATED OTHERWISE DIMENSIONS ARE IN INCHES	MATERIAL:	HDPE			TITLE:	SS SERIES GRAVITY OIL / SEDIMENT INTERCEPTOR	SERIES:	SS SERIES	REV:	 WWW.TANDCPLASTICS.COM 732-780-5300
	WEIGHT [lb]:	NAME	DATE	SHEET 1 OF 1			SIZE:			
	DO NOT SCALE DRAWING	DRAWN	DR	11/15/2022			SCALE: 1:2			

THE INFORMATION CONTAINED IN THIS DRAWING IS THE SOLE PROPERTY OF TOWN & COUNTRY PLASTICS LLC. ANY REPRODUCTION IN PART OR AS A WHOLE WITHOUT THE WRITTEN PERMISSION OF TOWN & COUNTRY PLASTICS LLC IS PROHIBITED.