

LID INSTALLATION DETAILS

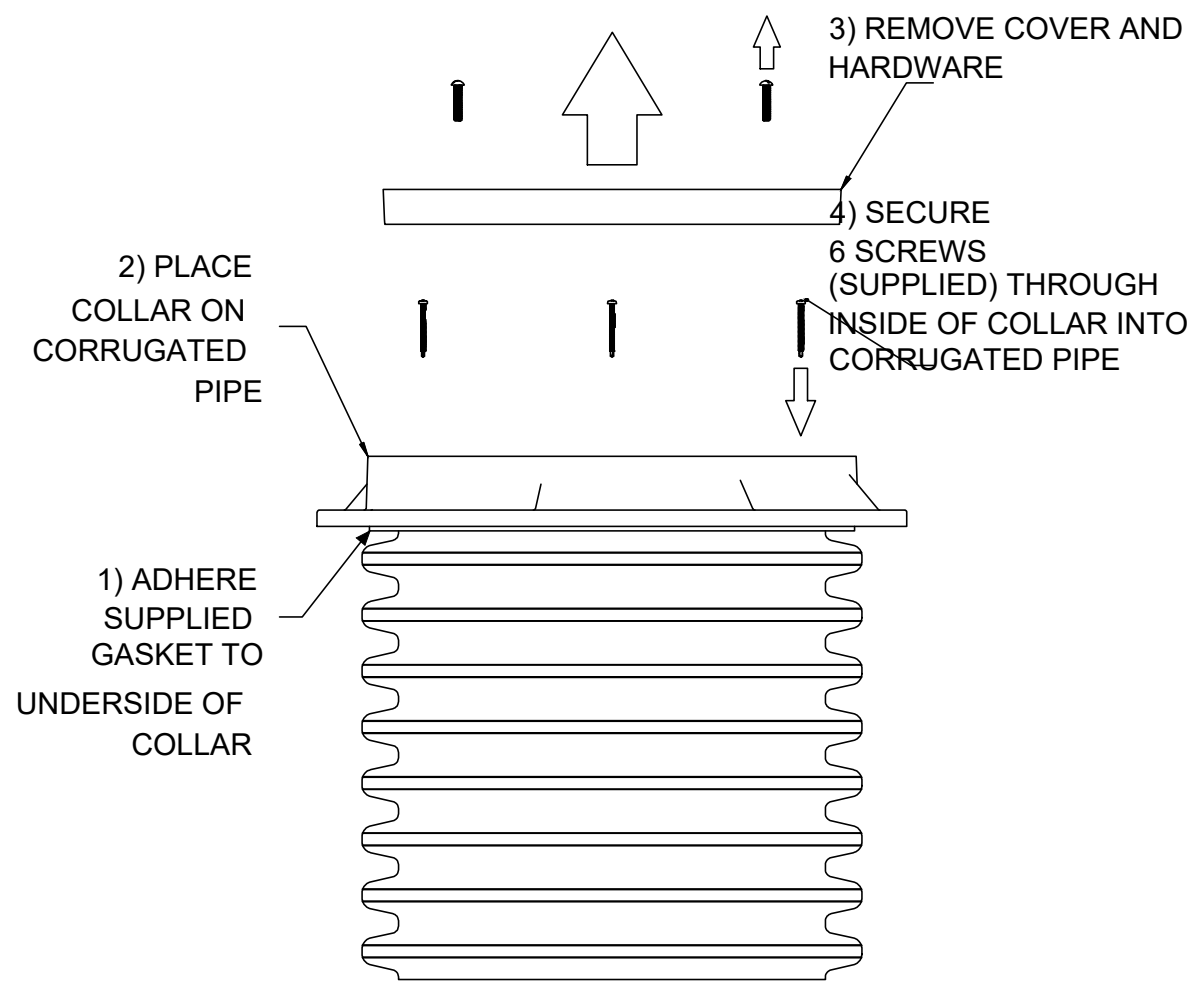

ANCHOR FLANGE AND MEMBRANE CLAMP DETAILS

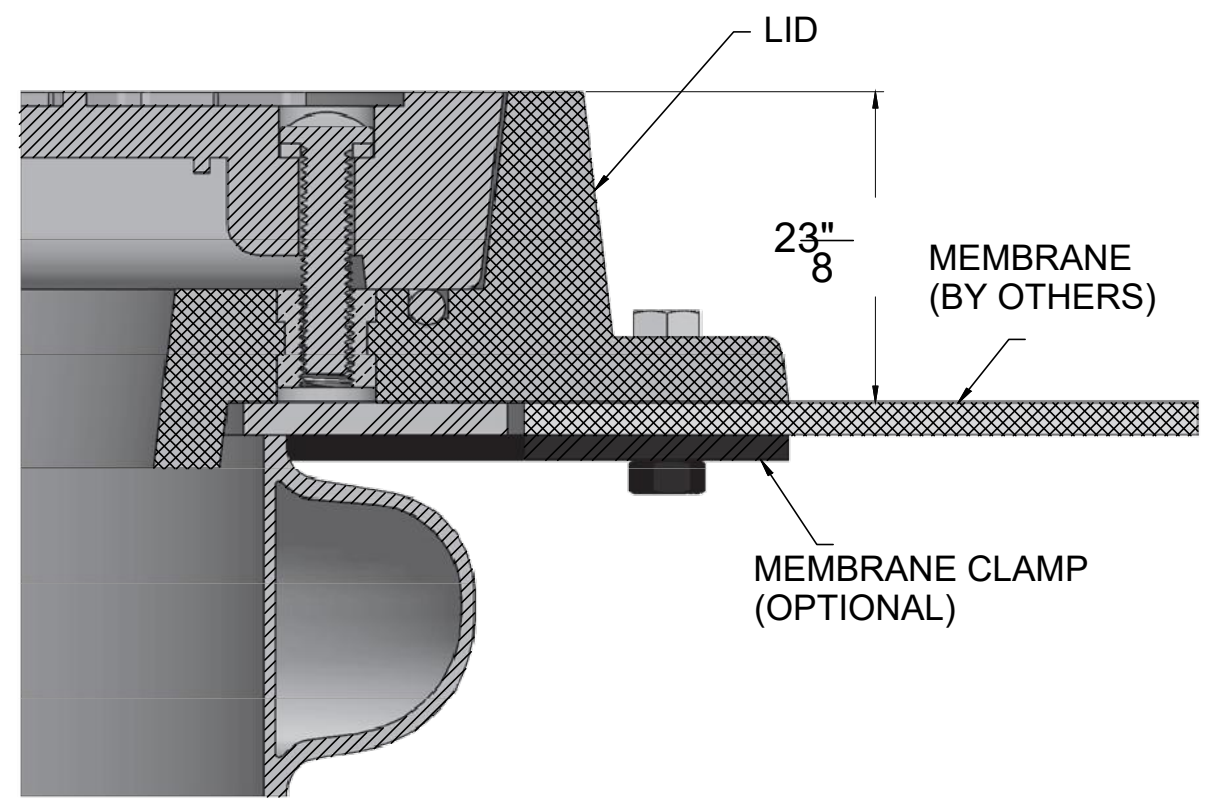

PLAN VIEW OF COLLAR

DRILLING POSITION FOR SCREWS WILL BE FOUND UNDER LID (6 HOLES)

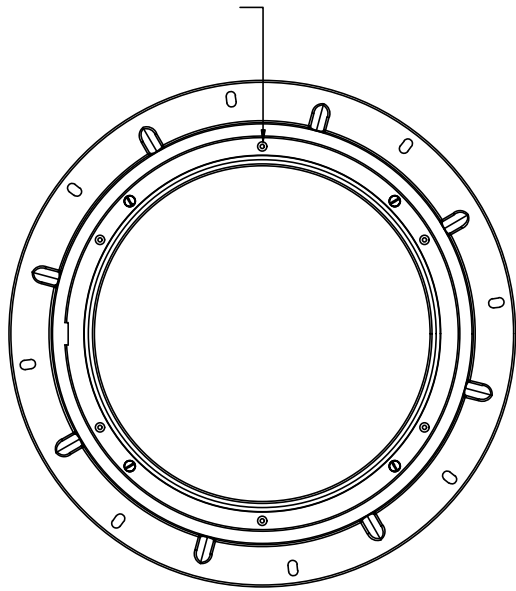

CROSS SECTION VIEW OF STEP 4

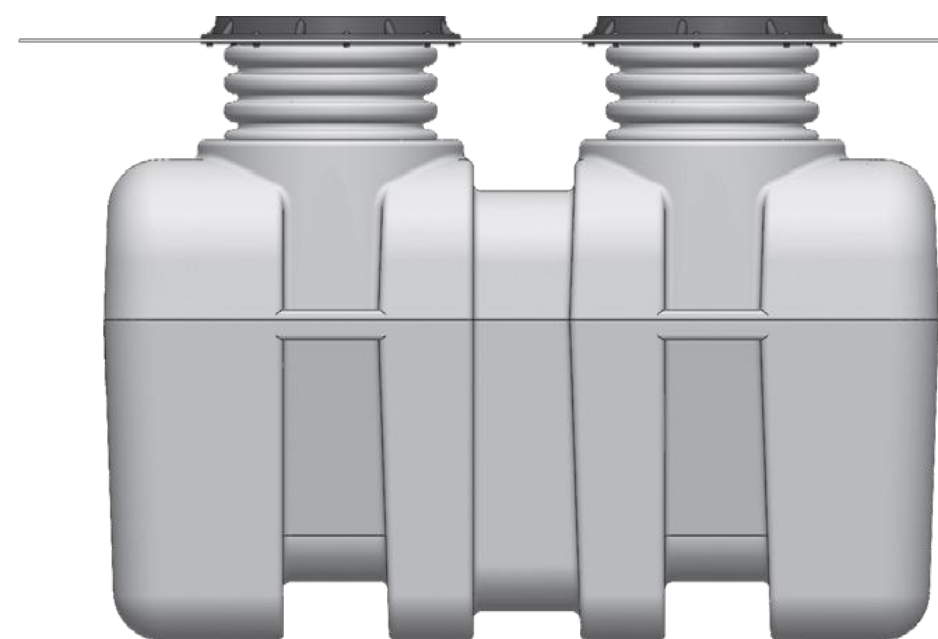
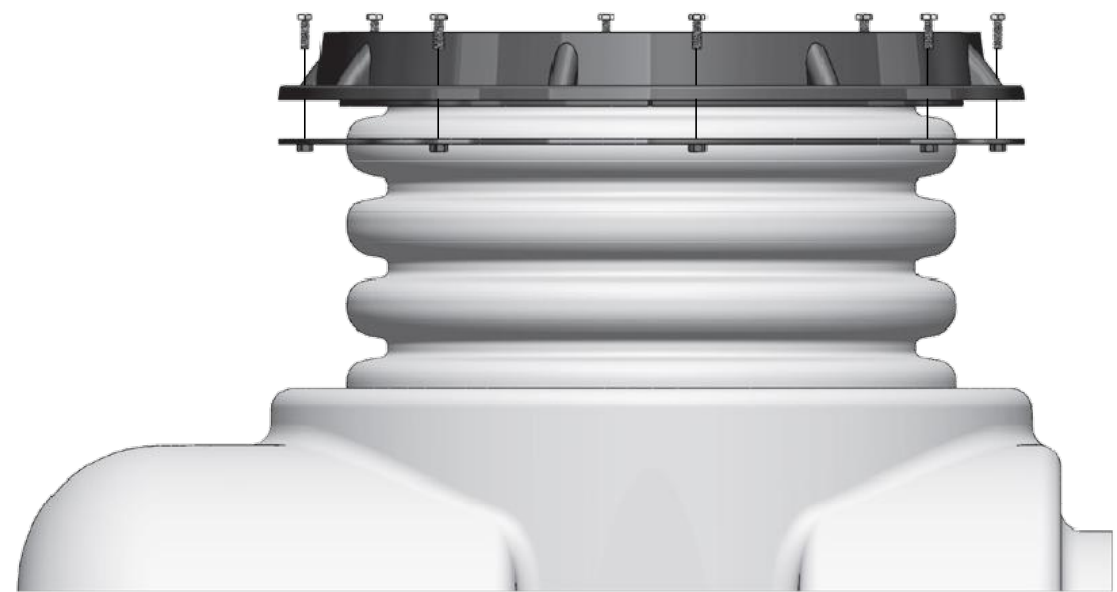
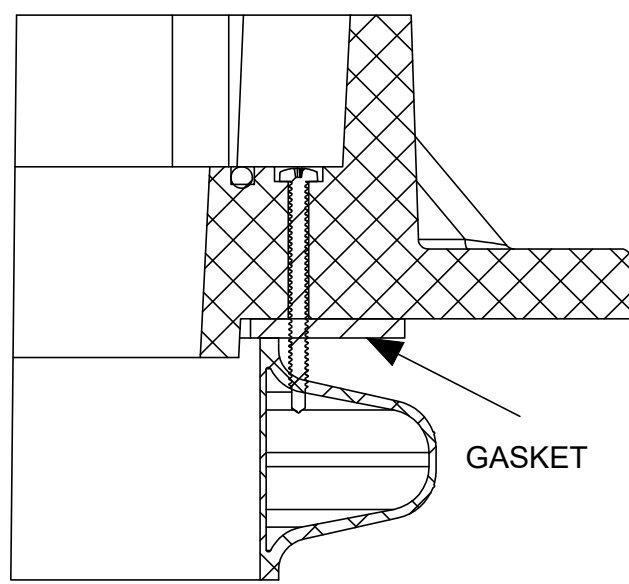

UNLESS STATED OTHERWISE DIMENSIONS ARE IN INCHES	MATERIAL: HDPE		TITLE: XL & SS LID INSTALL		SERIES: INTERCEPTORS	REV:	 WWW.TANDCPLASTICS.COM 732-780-5300
	WEIGHT [lb]:	NAME: DRAWN DR	DATE: 10/18/2022		SHEET 1 OF 1	SIZE:	
	DO NOT SCALE DRAWING	CHECKED:			SCALE: 1:2		

THE INFORMATION CONTAINED IN THIS DRAWING IS THE SOLE PROPERTY OF TOWN & COUNTRY PLASTICS LLC. ANY REPRODUCTION IN PART OR AS A WHOLE WITHOUT THE WRITTEN PERMISSION OF TOWN & PLASTICS LLC IS PROHIBITED.