

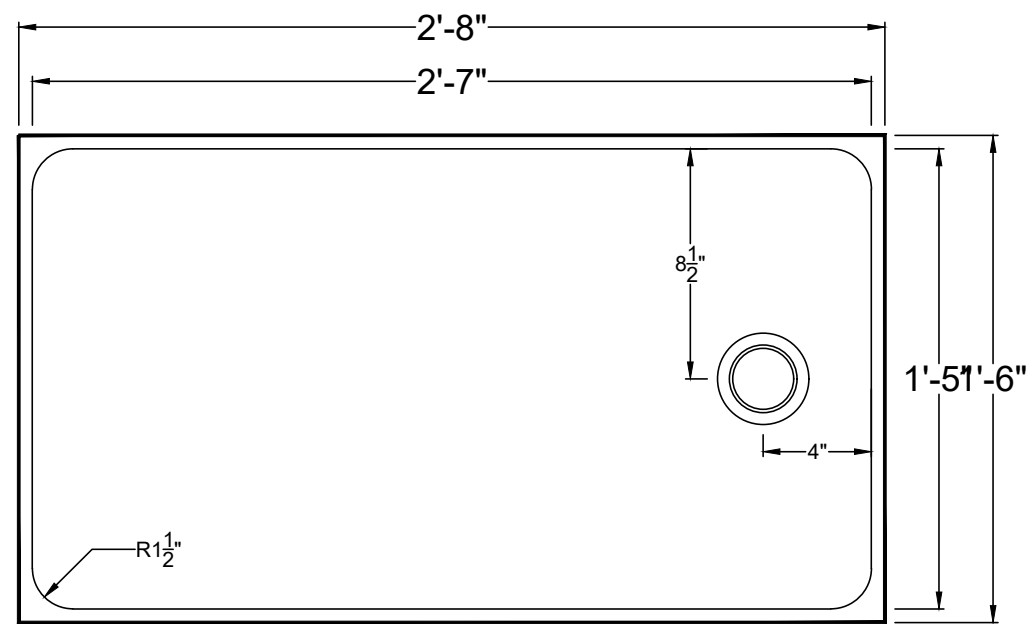

SECTION VIEW

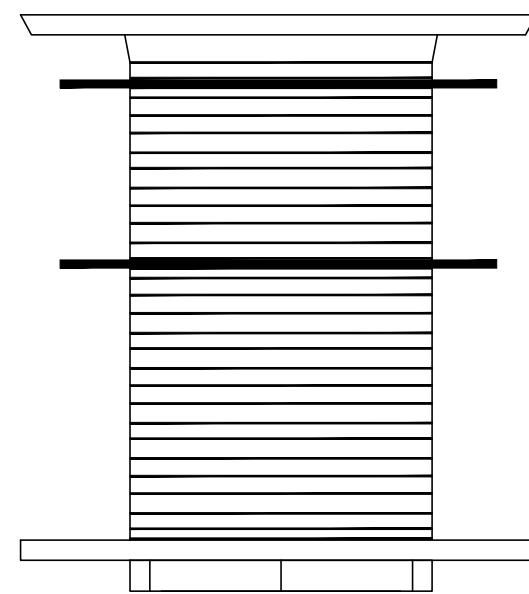

TOP VIEW

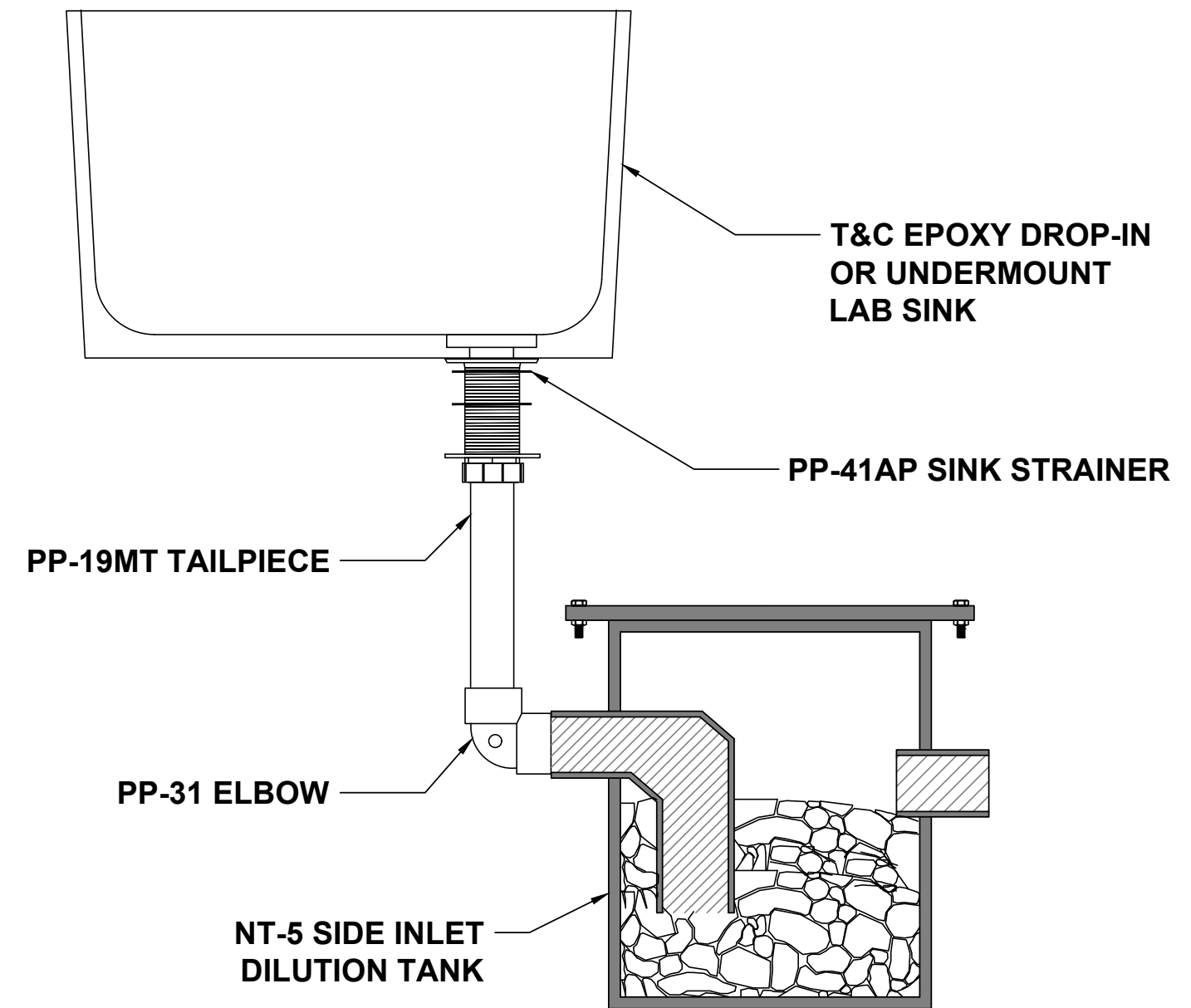

PP-41AP

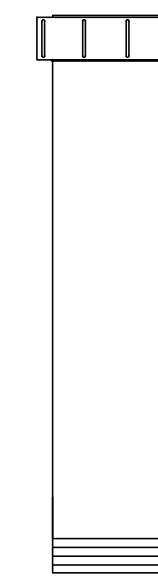

PP-19MT

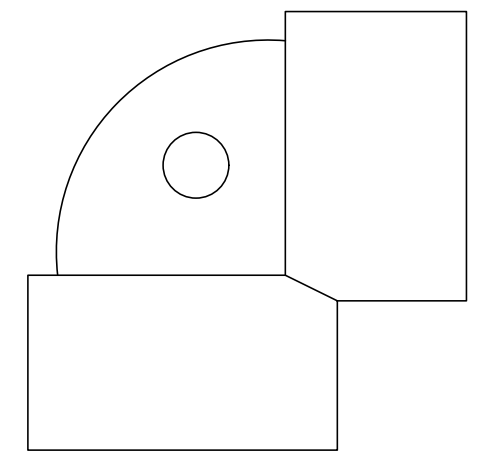

PP-31

NOTES:

| | | | |
|--|----------------------|-------|------------|
| UNLESS STATED OTHERWISE DIMENSIONS ARE IN INCHES | MATERIAL: | | |
| | WEIGHT [lb]: | NAME | DATE |
| | DO NOT SCALE DRAWING | DRAWN | DR |
| | CHECKED | | 03/01/2023 |

TITLE: **UNDERMOUNT SINK**

U63E
SHEET 1 OF 1
SCALE: N/A

REV:
SIZE:
T&C PLASTICS
WWW.TANDCPLASTICS.COM
732-780-5300

THE INFORMATION CONTAINED IN THIS DRAWING IS THE SOLE PROPERTY OF TOWN & COUNTRY PLASTICS LLC. ANY REPRODUCTION IN PART OR AS A WHOLE WITHOUT THE WRITTEN PERMISSION OF TOWN & PLASTICS LLC IS PROHIBITED.