

**SECTION VIEW**

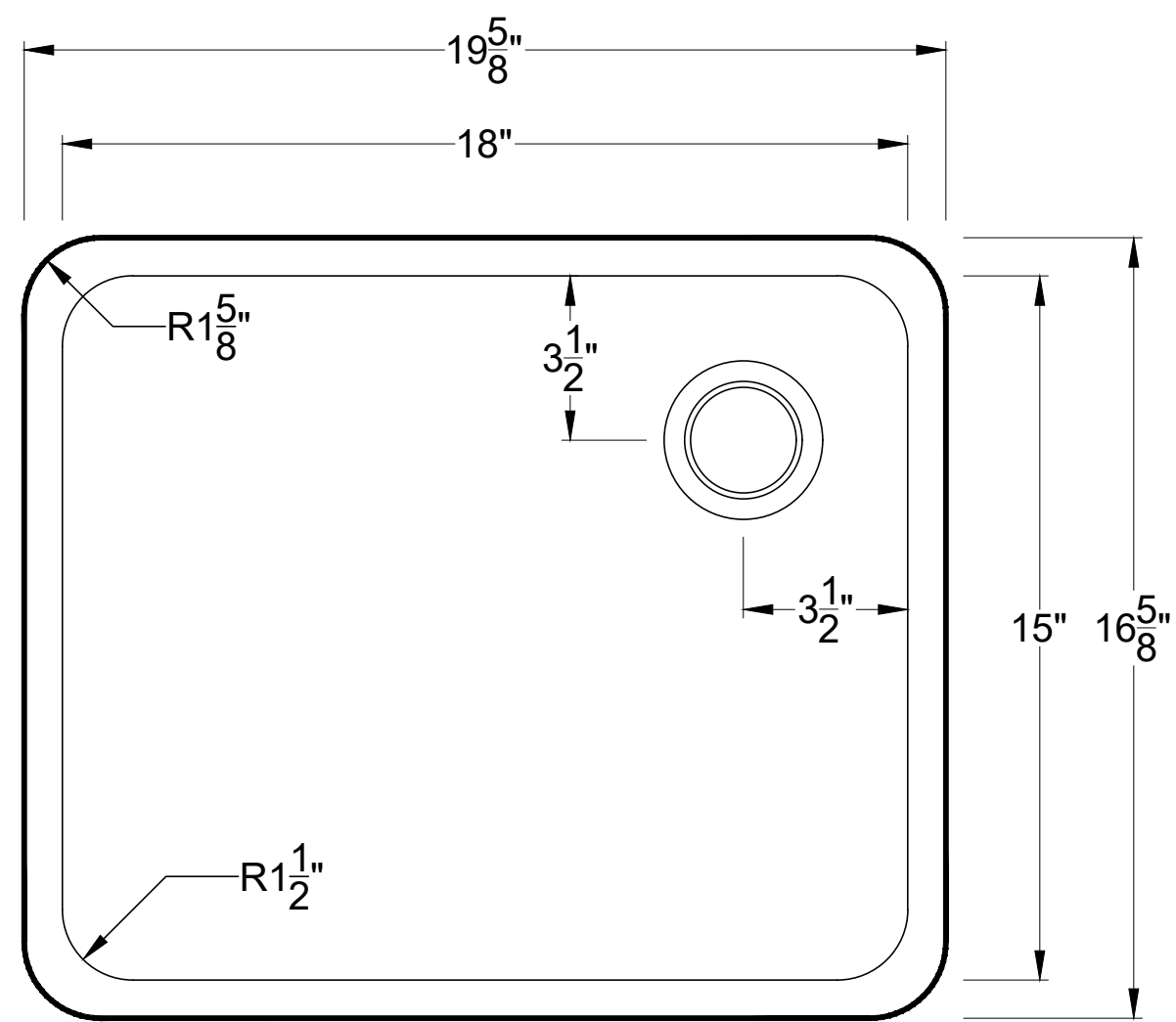

**TOP VIEW**

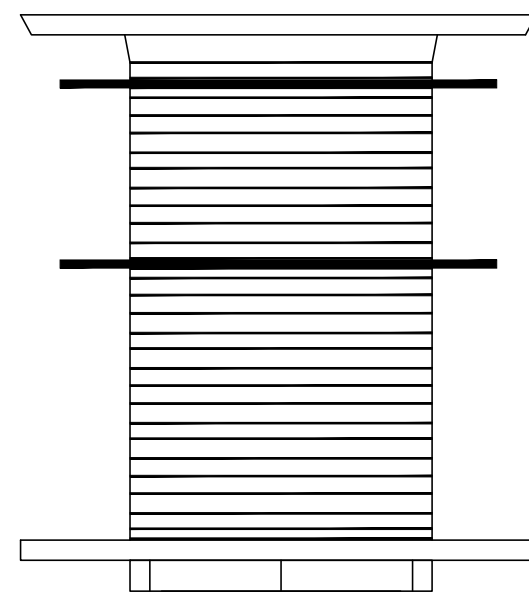
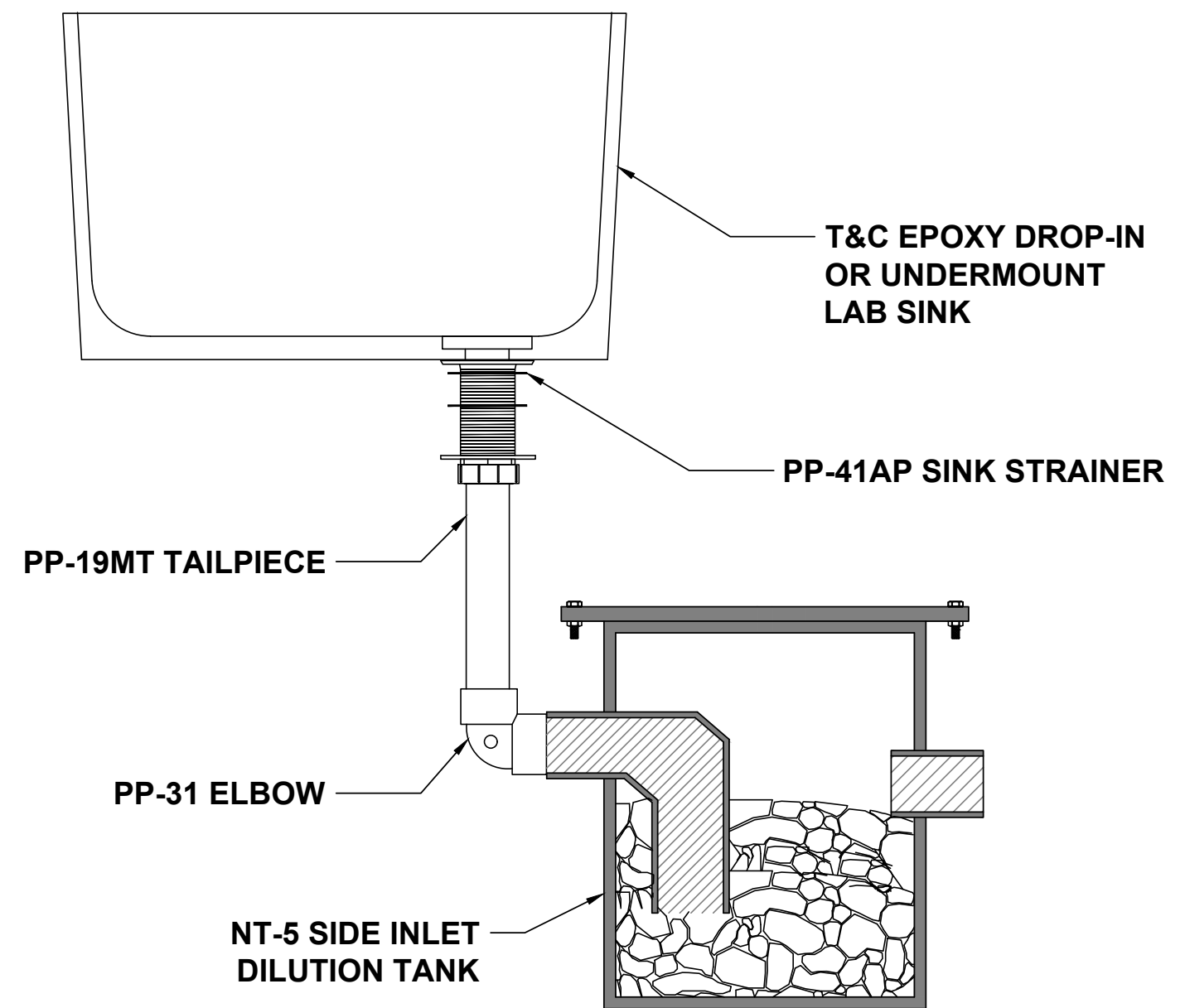

**PP-41AP**

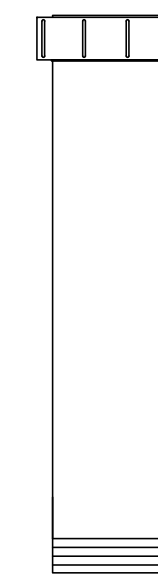

**PP-19MT**

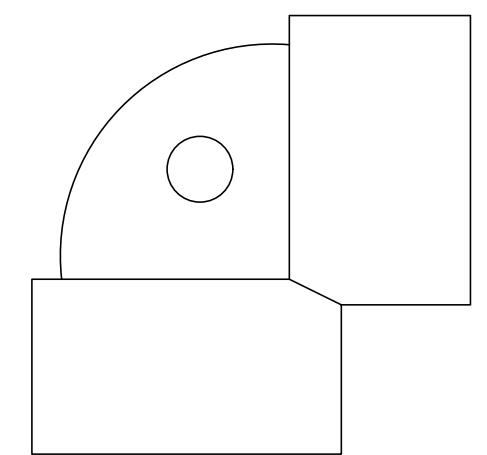

**PP-31**

NOTES:

UNLESS STATED OTHERWISE DIMENSIONS ARE IN INCHES	MATERIAL:		
	WEIGHT [lb]:	NAME	DATE
	DO NOT SCALE DRAWING	CHECKED	

TITLE: **DROP IN SINKS**

**D-25**  
SHEET 1 OF 1  
SCALE: N/A

REV: **T&C PLASTICS**  
SIZE: **WWW.TANDCPLASTICS.COM**  
**732-780-5300**

THE INFORMATION CONTAINED IN THIS DRAWING IS THE SOLE PROPERTY OF TOWN & COUNTRY PLASTICS LLC. ANY REPRODUCTION IN PART OR AS A WHOLE WITHOUT THE WRITTEN PERMISSION OF TOWN & PLASTICS LLC IS PROHIBITED.