

**SECTION VIEW**

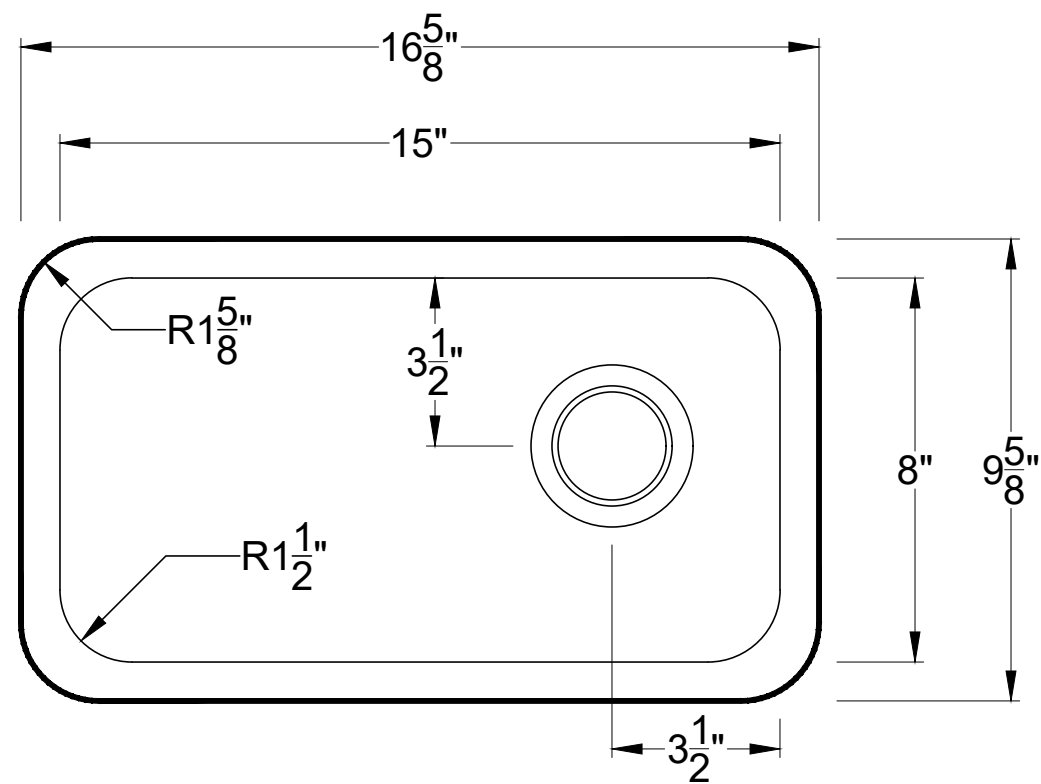

**TOP VIEW**

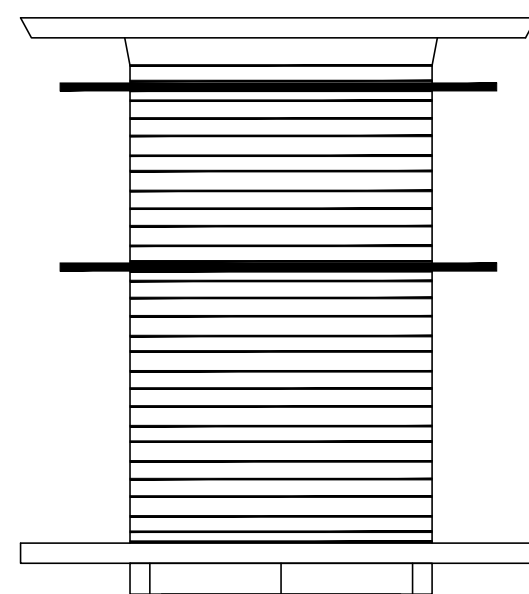
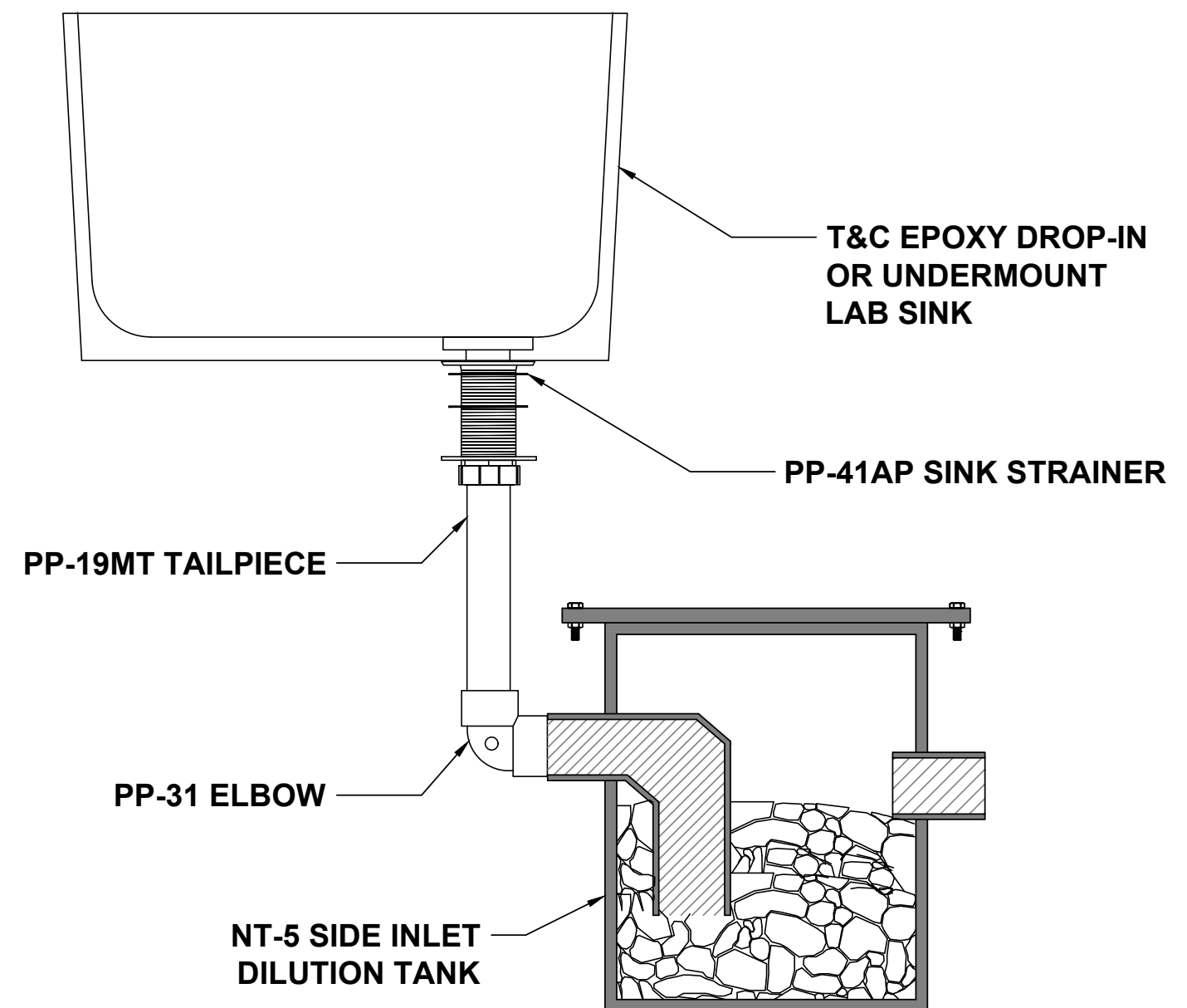

**PP-41AP**

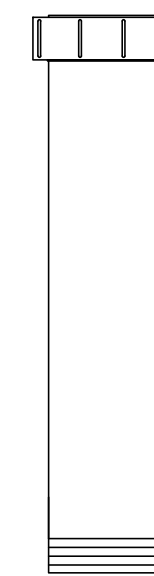

**PP-19MT**

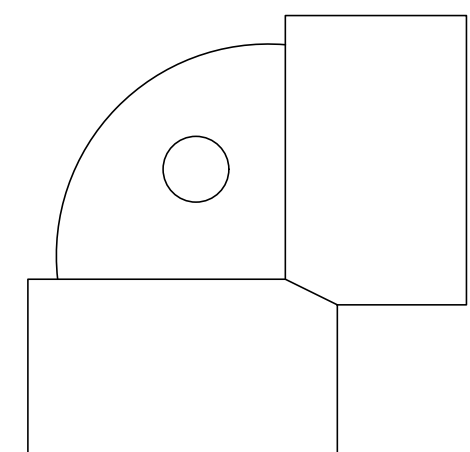

**PP-31**

**NOTES:**

UNLESS STATED OTHERWISE DIMENSIONS ARE IN INCHES	MATERIAL:		
	WEIGHT [lb]:	NAME	DATE
	DO NOT SCALE DRAWING	CHECKED	

TITLE:	<b>DROP IN SINKS</b>
REV:	
SIZE:	

<b>D-08</b>
SHEET 1 OF 1
SCALE: N/A

**T&C PLASTICS**  
 WWW.TANDCPLASTICS.COM  
 732-780-5300

THE INFORMATION CONTAINED IN THIS DRAWING IS THE SOLE PROPERTY OF TOWN & COUNTRY PLASTICS LLC. ANY REPRODUCTION IN PART OR AS A WHOLE WITHOUT THE WRITTEN PERMISSION OF TOWN & PLASTICS LLC IS PROHIBITED.